

SCHMIDT® Rotary indexing systems

For efficient production

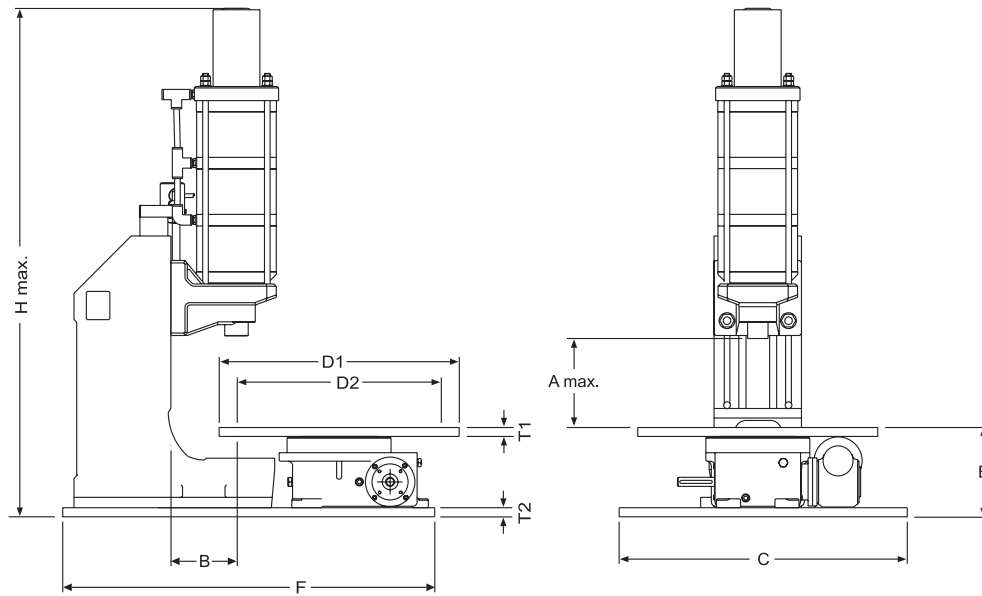

Press #	Press Force (lbs)	A max.	B	C	D1	D2	E	F	H max.	T1	T2
20	350	7.57	3.40	32	17	14.5	8.19	24	26.00	0.50	0.75
23	990	7.18	3.40	32	17	14.5	8.19	24	27.00	0.50	0.75
24	1,870	7.18	3.40	32	17	14.5	8.19	24	29.00	0.50	0.75
25	2,750	7.18	3.40	32	17	14.5	8.19	24	34.00	0.50	0.75
27	4,400	8.64	5.15	24	21	17.0	8.19	32	39.00	0.50	0.75
29	7,040	10.54	5.50	24	21	17.0	8.19	32	45.25	0.50	0.75
32	3,300	7.19	3.40	32	17	14.5	8.19	24	32.00	0.50	0.75
33	3,300	10.33	3.40	32	17	14.5	8.19	24	37.00	0.50	0.75
34	6,160	7.86	5.15	24	21	17.0	8.19	32	37.50	0.50	0.75
36	13,200	9.74	6.30	24	21	17.0	8.19	32	41.00	0.50	0.75
61	3,300	7.86	5.15	24	21	17.0	8.19	32	41.5	0.50	0.75
62	6,700	7.86	5.15	24	21	17.0	8.19	32	42.50	0.50	0.75
65	11,440	9.26	6.30	24	21	17.0	8.19	32	34.00	0.50	0.75
68	15,840	10.66	6.30	24	21	17.0	8.19	34	43.30	0.50	0.75
64	22,400	12.05	6.30	24	21	17.0	9.02	36	59.17	0.50	0.75

SCHMIDT Technology has developed two standard, off-the-shelf Indexing Systems. One Indexing System fits the smaller C-frame mounted Direct-Acting Pneumatic Presses No. 20 – 25 and precision Air Toggle Presses No. 32 and 33. The other Indexing System will work on all larger Direct-Acting Pneumatic, Air Toggle and Hydro-Pneumatic Presses.

Featuring a precision roller cam indexing drive chassis with variable speed control, these standard Indexing Systems are available with 4, 6, 8, 12 or 24 indexing positions. Indexing Systems are equipped with user-friendly PLC-based controls for 1 x 115 volt/60Hz operation. Custom tooling, light curtain guarding, automatic loading and unloading devices and ergonomic workstations (Model PU-1, PU-2 or PU-10) are optional.

